

Feeder Pan Suspension Scheme

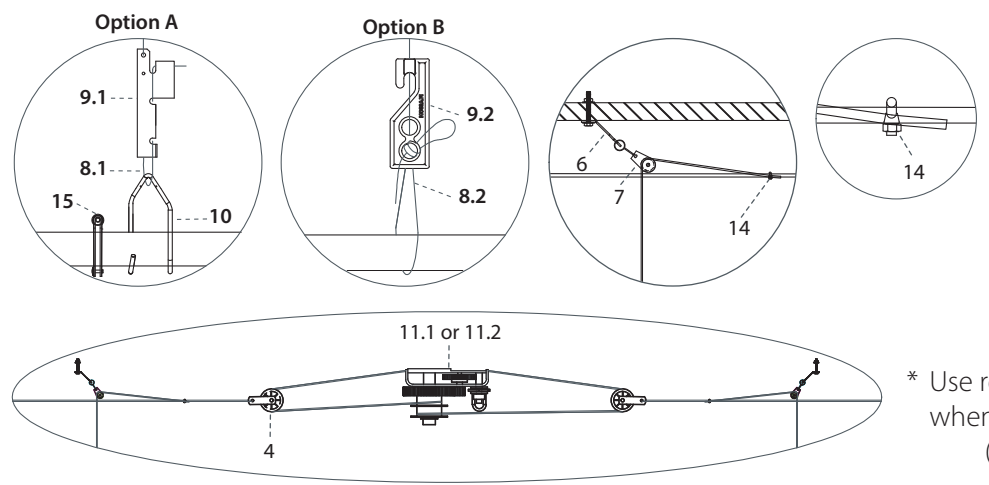
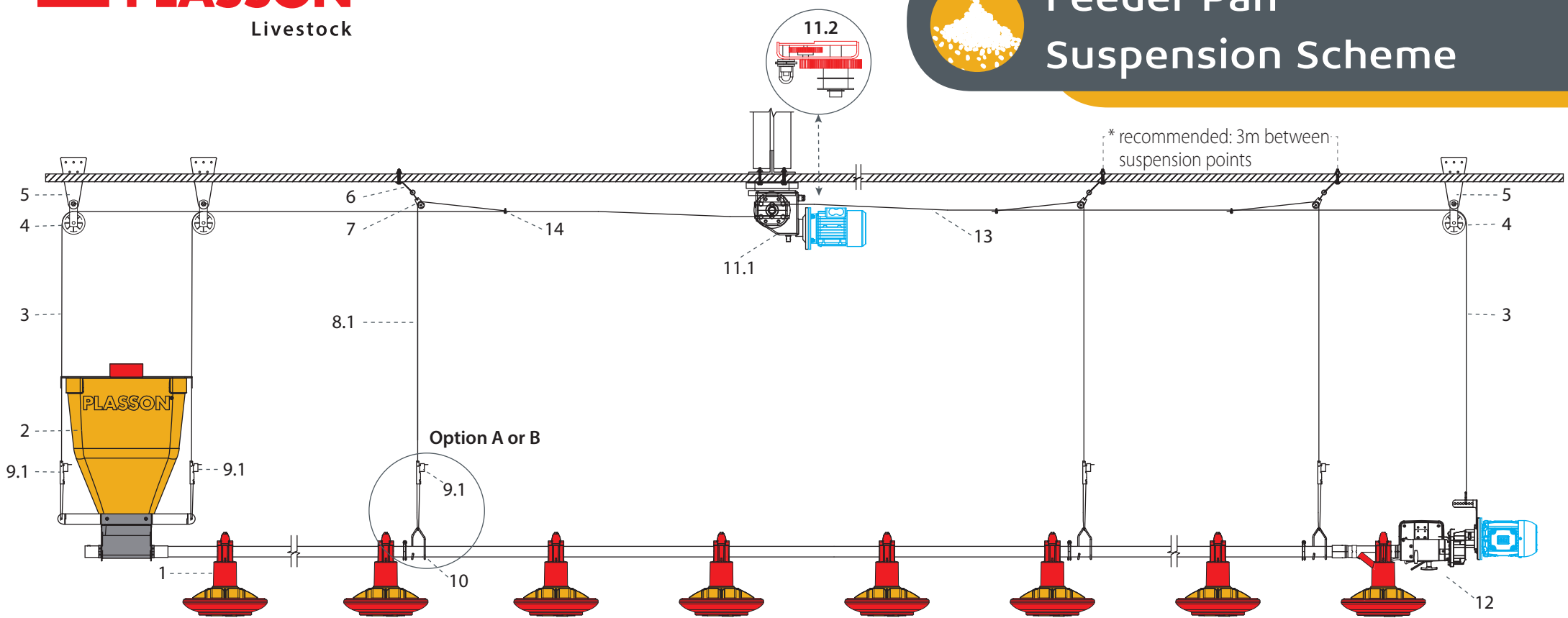

Item	Item Code	Description	Note
1		Feeder Pan	Various options
2		Hopper	Various options
3	02205605	Cable 1/8" 7x7 per meter	
4	02310020	Steel pulley 3.1/2"	
5	02312569	End line pulley suspension	
6.1	02312006	Ceiling hook for metal house	According to house
6.2	02312005	Ceiling hook for concrete house	
7	02310359	Nylon pulley 1-7/8"	
8.1	02320003	Steel cable 3/32" (2.4mm) (A)	Optional: 8.2 Cord (100m) (B)
9.1	02310457	Cable height adjuster (A)	Optional: 9.2 Cord adjuster (B)
10	02310195	Hanger for round feeder pipe	Not needed in B
11.1	02312500	Feeder electric winch	Optional: 11.2 Feeder manual line double winch (02310560)
12		Control unit	Various options
13	02320002	Steel cable 3/16"	
14	02310023	Cable clamp 3/16"	
15	02310008	Galv. pipe clamp	

* Use reduction system when line is over 30 m (02310524)